



## All Ways

**Designed by:** CRS albed

**Typology:** Perete divisoria | Partition wall | Paroi de separation | Trennwand | Pared divisoria

Il sistema All Ways è l'ideale per dividere e organizzare gli ambienti di lavoro.

The system All Ways is suitable for separating and organizing the workplace.

Le système All Ways est idéal pour la séparation et l'organisation du travail.

Das System All Ways ist ideal zum Trennen und Organisation des Arbeitsplatzes.

El sistema All Ways es ideal para separar y organizar el lugar de trabajo.

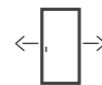

All Ways, finitura  
profili neri e vetro  
neutro. Porta battente  
a tutta altezza.



All Ways, finitura profili neri e  
vetro neutro. Porta battente a  
tutta altezza.

All Ways, finition profils noir  
et verre neutro. Porte battante  
toute hauteur.

All Ways, Ausführung Rahmen  
Schwarz und Klarglas.  
Drehtür ganze Höhe.

Sistema All Ways con perfiles  
negros y vidrio transparente.  
Puerta batiente a toda altura.



All Ways, nella versione con porta scorrevole. Finitura profili bronzo e vetro neutro. Tecnicità rivisitata in ambiente domestico.

All Ways system with sliding door version. Profiles in bronze and transparent glass. Revisited technicalness in domestic environment.

All Ways dans la version avec porte coulissante. Finition profils bronze et verre neutre. Technicité au service de la maison.

All Ways, in der Version mit Schiebetür. Ausführung Rahmen Bronze und Glas extra hell. Neu interpretierte Technik für das Haus.

Sistema All Ways en la versión con puerta corredera. Acabado perfiles en bronce y vidrio transparente. Detalles técnicos reeditados en el ámbito doméstico.





All Ways , finitura profili alluminio, vetro neutro e vetro acidato ai lati. Possibilità di utilizzo vetri stratificati che oltre a garantire sicurezza assicurano ottimi abbattimenti acustici (40).

All Ways system with aluminium profiles, transparent glass in the front and frosted glass on the sides. Possibility for using of stratified glasses which guarantee safety and excellent acoustic isolation (40).

All Ways, finition profils aluminium, verre neutro et acidé sur les côtés. Possibilité d'utiliser verre stratifiés pour avoir soit de la sureté que isolation acoustique (40).

All Ways, Ausführung Rahmen Aluminium, Klarglas und Glas satiniert auf den Seiten. Möglichkeit Verbindgläser zu benutzen, die Sicherheit und einen besseren Schallschutz versichern (40).

Sistema All Ways, acabado perfiles aluminio, vidrio transparente en frente y vidrio al ácido en los lados. Posibilidad de utilizar vidrios estratificados que garantizan seguridad y mejor aislamiento acústico (40).



Con l'assemblaggio di un unico profilo in alluminio, posizionabile orizzontalmente e verticalmente si ripartisce non solo, lo spazio in aree operative, sale riunioni, uffici ma è utilizzabile anche nella cornice di un living room in casa.

With the assembly of a single aluminium profile, which can be positioned horizontally or vertically, you can divide not only the space into operational areas, meeting rooms, offices, but at the same time, a home living room.

Avec l'assemblage d'un profilé d'aluminium unique, positionné horizontalement et verticalement, on distribue non seulement l'espace dans les zones opérationnelles, salles de réunion, des bureaux, mais également dans le cadre d'un séjour de la maison.

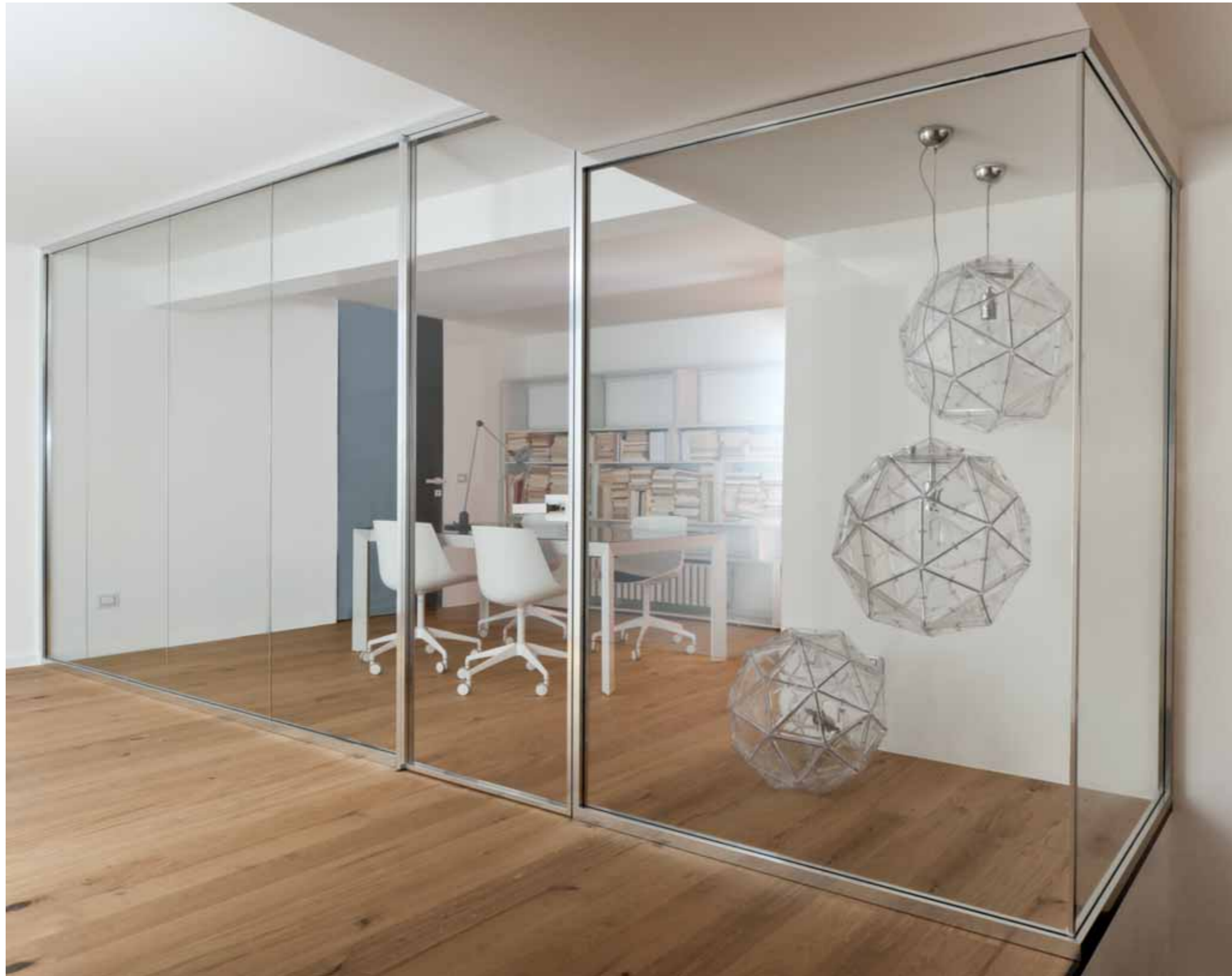

Bei der Montage eines einzigen Aluminiumprofil horizontal und vertikal positioniert, verteilt man nicht nur Platz in den operativen Bereichen, Konferenzräume, Büros, sondern auch in der Einstellung der Wohnzimmer im Haus.

Con el conjunto de un solo perfil de aluminio, posicionable horizontalmente y verticalmente, no sólo se distribuye el espacio en las áreas de operaciones, salas de reuniones, oficinas, también puede ser utilizado en el contexto de una sala de estar en la casa.

## Always

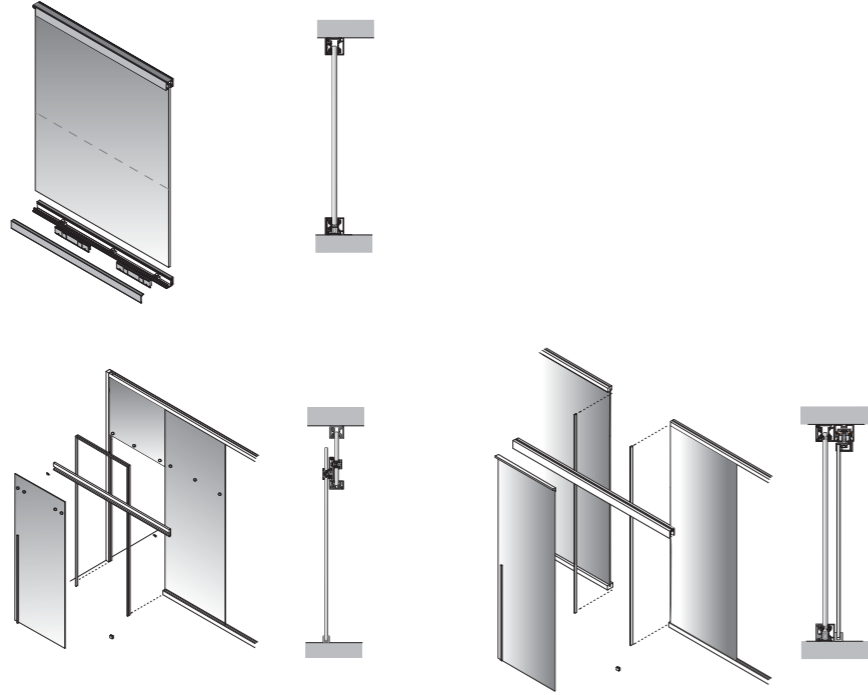

Porta scorrevole | Sliding door | Porte coulissante | Schiebetür | Puerta corredera

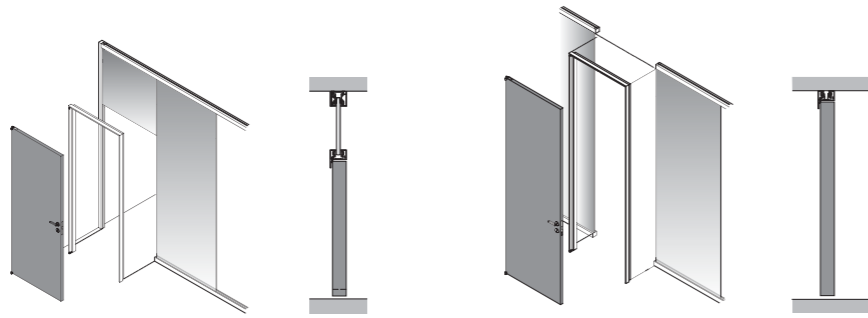

Porta battente | Swing door | Porte battante | Drehtüren | Puerta batiente

Dettaglio montante terminale | Detail for terminal profile | Détail du montant terminal  
Detail des Endpfostens | Detalle montante terminal

Dettaglio angolo a 90° | Detail for 90° angle | Détail angle à 90° | Detail der Ecke 90° | Detalle ángulo de 90°

Particolare maniglia | Detail of the handle | Détail de la poignée | Detail des Griffes | Detalle del tirador



# finiture

Stipiti, telaio porta, montanti e struttura tavolo | Door jambs, door frame, uprights and table structure | Jambage, cadre de porte, montants et structure de la table | Türpfosten, Türrahmen, Pfosten und Tischstruktur | Jambas, marco de puerta, montantes y estructura de la mesa.

	level	ring	blow	integra and	next	ri-trait	prima	quadra beat	quinta dot	sail	all ways boisè	vista girevole ri-vista solo	line	nile
alluminio		■	■			■	■	■	■	■	■	■	■	■
nero						■	■	■	■	■	■	■	■	■
bronzo						■	■	■	■	■	■	■	■	■
champagne						■	■	■	■	■	■	■	■	■
bianco	□			□	□							□	□	□
laccato ral	■			■	■	■						■	■	■
frassino light														
wengè														■
noce canaletto														■

Pannello porta, schienali e accessori | Door jambs, door frame, uprights and table structure | Jambage, cadre de porte, montants et structure de la table | Türpfosten, Türrahmen, Pfosten und Tischstruktur | Jambas, marco de puerta, montantes y estructura de la mesa.

	level	ring	blow	integra and	next	ri-trait	prima	quadra beat	quinta dot	sail	all ways boisè	vista girevole ri-vista solo	line	nile
fango				■	■			■				■	■	■
testa di moro				■	■			■				■	■	■

Pannello porta, schienali e attrezzature in legno | Door panel, seatbacks and wooden equipment | Panneau de porte, dossiers et équipement en bois | Türverkleidung, Sitzrücken und Holz-ausrüstung | Panel de puerta, respaldos y equipo en madera

	level	ring	blow	integra and	next	ri-trait	prima	quadra beat	quinta dot	sail	all ways boisè	vista girevole ri-vista solo	line	nile
laccato ral	■	■	■	■	■	■						■	■	■
wengè	■		■	■	■	■						■	■	■
noce canaletto	■		■	■	■	■						■	■	■
frassino light	■		■	■	■	■						■	■	■
frassino lounge	■		■	■	■	■						■	■	■
frassino carbone	■			■	■	■						■	■	■
frassino grey	■		■	■	■	■						■	■	■
eucalyptus	■		■	■	■	■						■	■	■
pino con nodi	■		■	■	■	■						■	■	■
rovere termotr.	■		■	■	■	■						■	■	■
bianco acrilico														
ardesia	■			■										
nobilitato bianco												□	□	□
nobilitato louvre												■	■	■
nobilitato carbone												■	■	■
nob. light forest												■	■	■
nob. mid forest												■	■	■
nob. dark forest												■	■	■





Stampa vetro su extrachiaro | Printing on extrachiaro glass | Impression sur verre extrachiaro | Druck auf Glas Extrachiaro | Impresión en vidrio extrachiaro

level ring blow integra and next ri-trait prima quadra beat quinta dot sail all ways boisè vista girevole ri-vista solo line nile

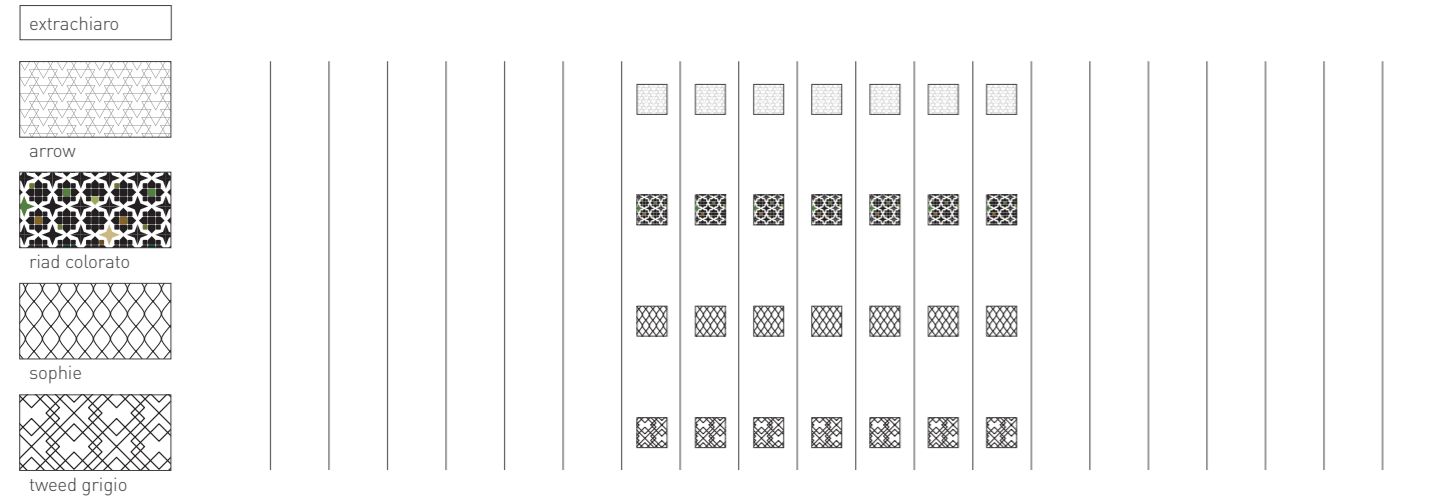

Stampa su bronzo acidato | Printing on bronze etched glass | Impression sur verre bronze acidato | Drucken auf Bronze Acidato Glas (gefrostet) | Impresión en vidrio bronzo acidato

level ring blow integra and next ri-trait prima quadra beat quinta dot sail all ways boisè vista girevole ri-vista solo line nile

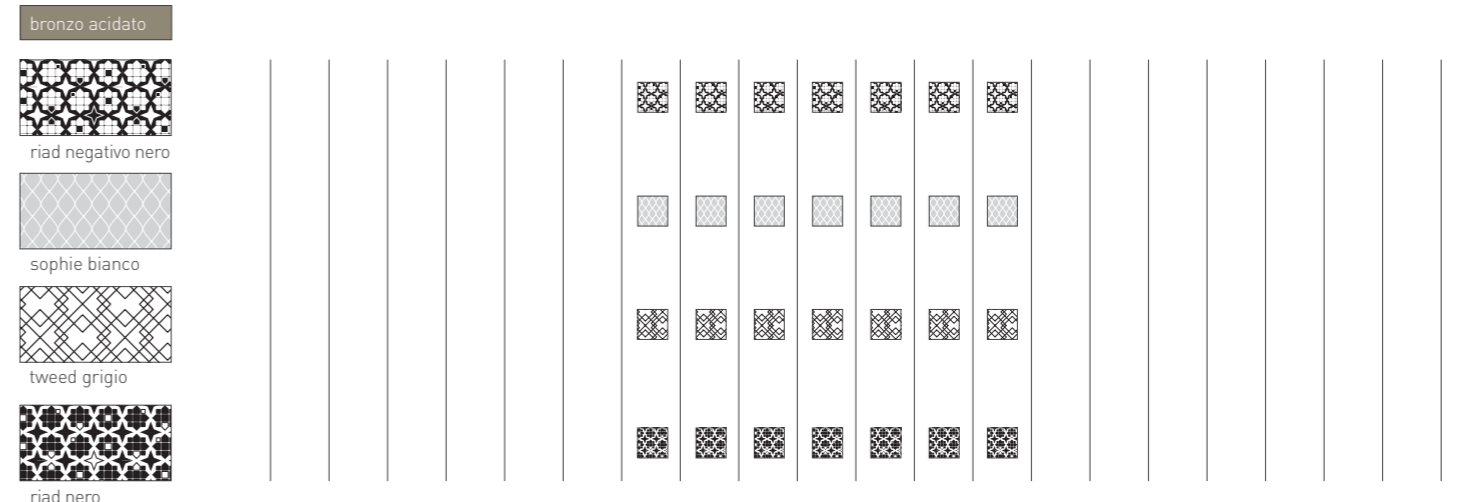

Stampa su vetro acidato extrachiaro | Printing on extrachiaro-etched glass | Impression sur verre acidato extrachiaro | Druck auf Glas Acidato Extrachiaro (gefrostet) | Impresión en vidrio extrachiaro acidato

level ring blow integra and next ri-trait prima quadra beat quinta dot sail all ways boisè vista girevole ri-vista solo line nile

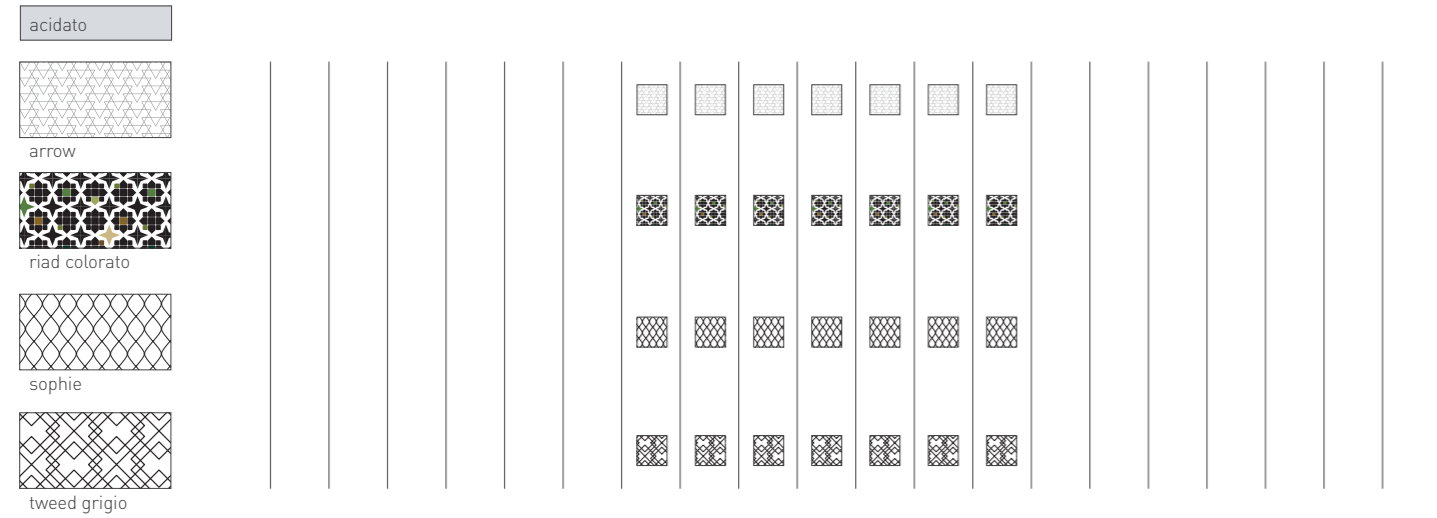

Stampa su vetro fumè acidato | Printing on smoked frosted glass | Impression sur verre fumè acidato | Druck auf Fumé Glas (gefrostet) | Impresión en vidrio fumè acidato

level ring blow integra and next ri-trait prima quadra beat quinta dot sail all ways boisè vista girevole ri-vista solo line nile

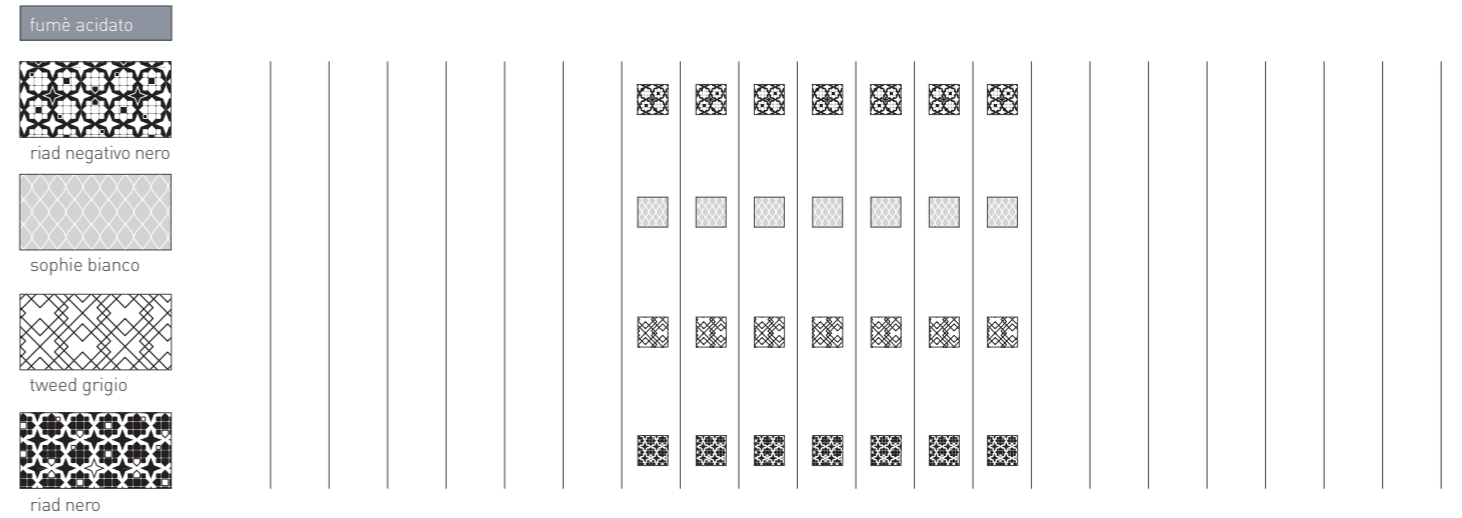





















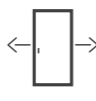

Pannello porta e schienali | Door panel, seatbacks and wooden equipment | Panneau de porte et dossier | Türverkleidung und Rückwaende | Panel de puerta y respaldo

	level	ring	blow	integra and	next	ri-trait	prima	quadra	beat	quinta	dot	sail	all ways	boisé	vista girevole	ri-vista	solo	line	nile	
fabric white																				
fabric black																				
alu natural mesh																				
gold mesh																				
tweed metal mesh																				
deluxe gold																				
deluxe silver																				

Mensole in vetro | Door jambs, door frame, uprights and table structure | Jambage, cadre de porte, montants et structure de la table | Türpfosten, Türrahmen, Pfosten und Tischstruktur | Jambas, marco de puerta, montantes y estructura de la mesa.

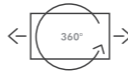
	level	ring	blow	integra and	next	ri-trait	prima	quadra	beat	quinta	dot	sail	all ways	boisé	vista girevole	ri-vista	solo	line	nile	
neutro extrach.																				
fumè																				
bronzo																				
dark grey																				
acidato																				
fumè acidato																				
bronzo acidato																				

# legenda simboli

 <p>Apertura cerniere 180° Opening of the hinges 180° Ouverture des charnières 180° Öffnung der Scharniere 180° Apertura bisagras de 180°</p>	 <p>Stipite telescopico Telescopic jamb Montant télescopique Teleskopischer Pfosten Jamba telescópica</p>	 <p>Cerniera regolabile Adjustable hinge Charnière réglable Verstellbare Scharniere Bisagra regulable</p>	 <p>Stipiti in alluminio Jambas in aluminium Montants en aluminium Pfosten aus Aluminium Jambas de aluminio</p>
 <p>Serratura magnetica Magnetic lock Serrure magnétique Magnetisches Schloß Cerradura magnética</p>	 <p>Installazione su muratura o cartongesso Installation on brick or plasterboard Application sur mur ou placoplâtre Montage an die Wand oder Gipskarton Instalación en pared de ladrillo o cartonyeso</p>	 <p>Su misura Custom-made Sur mesure Nach Maß A medida</p>	 <p>Versione a tirare e a spingere Version to pull and to push Version à tirer ou à pousser Ausführung zum Ziehen oder zum Drücken Versión a tirar y a empujar</p>
 <p>Possibilità di inserire serratura Lock may be inserted Possibilité de serrure Schloßmöglichkeit Posibilidad de insertar la cerradura</p>	 <p>Insonorizzante Soundproofed Insonorisation Schalldämmung Insonorización</p>	 <p>Antincendio Fire door Résistant au feu Feuerfest Antiincendio</p>	 <p>Paraspifferi Retractable strip Joint rétractable Zugluftstopperr Burlete</p>
 <p>Porta battente corridoio Corridor door Porte battante couloir Drehtür Flur Puerta batiente pasillo</p>	 <p>Porta scorrevole Porte coulissante Sliding door Schiebetür Puerta corredera</p>	 <p>Porta battente Swing door Porte battante Drehtür Puerta batiente</p>	 <p>Rallentatore Slow-Motion Ralentisseur Verlangsamerr Freno</p>
 <p>Vetro di sicurezza Safety glass Verre de sécurité Sicherheitsglas Vidrio de seguridad</p>	 <p>Filomuro da entrambi i lati Flush door on both sides Ras du mur des deux cotés Beidseitig wandbündig Puerta enrasada a la pared por ambos los lados</p>	 <p>Possibilità di arrivare a soffitto Possibility of all height door Possibilité de toute hauteur Ganze Höhe möglich Posibilidad de puertas hasta el techo</p>	 <p>Binario ad incasso Built-in rail Rail encastré Eingelassene Schiene Guía empotrada</p>
 <p>Rotazione a 360° e scorrimento laterale 360° rotation and side sliding Rotation à 360° et coulissement latéralment 360°Drehung und Seitengleitung Rotación a 360° y deslizamiento lateral</p>	 <p>Binario ad incasso Built-in rail Rail encastré Eingelassene Schiene Guía empotrada</p>	 <p>Scorrimento a pavimento Slide on the floor Coulissement au sol Bodenlaufen Deslizamiento a suelo</p>	 <p>Chiudiporta integrato Built-in door closer Ferme- porte intégrée Eingelassener Türschließer Cierre automático de la puerta empotrado</p>

450 600 900 1200  
| | | |

Moduli  
Modules  
Modules  
Module  
Modulos